

M-661 · M-662

PILine® Miniature Linear Stages with Ultrasonic Piezo Linear Motors



PILine® M-662 (left side) and M-661 stages are the smallest piezo-motor-driven translation stages available on the market that achieve speeds of up to 500 mm/s.

- **Smallest Translation Stage with High-Speed Linear Motor Drive**
- **20 mm Travel Range**
- **Velocity to 500 mm/s**
- **Acceleration to 20 g**
- **Resolution to 50 nm**
- **Self-Locking**
- **XY-Combinations Available**
- **20,000 h MTBF**
- **Vacuum Versions to 10⁻⁷ hPa**

PILine® – Ultimate Motion in the Smallest Package

PILine® M-661- and M-662-series micropositioning systems are the smallest high-

speed piezo-motor-driven translation stages currently available on the market.

Working Principle

M-661 and M-662 stages have a new, patented, ultrasonic drive developed by PI. The highly compact, integrated P-661 piezomotor drive can provide accelerations of up to 20 g and velocities of 500 mm/s and more, together with high resolution and holding force. Because the ceramic stator is pressed against a slider of the stage, piezomotors resist motion with an intrinsic holding force when the stage is at rest. The result is very high position stability without the

heat dissipation common with conventional linear motors. Furthermore, there are no gears, leadscrews or other mechanical components to contribute play or backlash.

M-661 / M-662 Fast and Compact

Both models are operated without position feedback, where they can achieve speeds of up to 500 mm/s. The square footprint of the M-662.470 makes it suitable for XY-configurations, while the M-661.370, which is even smaller, is designed for single-axis systems.

Drive Electronics for Open-Loop Operation

Two different driver electronics solutions are available for PILine® open-loop stages and OEM motors. They can either be operated by a simple pulsed-mode driver (C-181), or by a more sophisticated version which allows controlling the speed with an analog signal in the ±10 V range (C-185).

C-181, C-170 – Pulsed Mode Operation

Pulsed operation is especially suited for applications requiring small steps or rapid end-to-end motion, as in microscopy, automation or similar applications.

The motor can be controlled with 5 V TTL pulses connected to the signal input on the driver electronics. The width of the pulses will determine the approximate length of the steps the motor makes. The smallest possible step is about 50 nm, requiring a pulse of about 10 μs in duration. The pulse rate and width can be used to influence the step size and rate, thus determining the velocity.

Ordering Information

- M-661.370**
PILine® Ultra-Compact Translation Stage with P-661 Piezo Linear Motor Drive, 18 mm Travel
- M-662.470**
PILine® Ultra-Compact Translation Stage with P-661 Piezo Linear Motor Drive, 20 mm Travel
- M-662.4V0**
Vacuum-compatible version of the M-662.470
- C-181.161**
Pulse-Mode Drive Electronics for PILine® P-661 Piezo Linear Motors or Translation Stages with P-661 Motors; with Power Supply
- C-185.161**
Analog Drive Electronics for PILine® P-661 Piezo Linear Motors or Translation Stages with P-661 Motors; with Power Supply
- C-170.161**
RedStone Open-Loop Piezomotor Controller/Driver, 1 Channel, for PILine® Systems with P-661 Motors
- C-170.261**
RedStone Open-Loop Piezomotor Controller/Driver, 1 Channel, for PILine® Systems with P-664 Motors

A flexible, programmable pulse generator with integrated C-181 driver is available as C-170.161.

C-185 Analog Driver

The C-185 analog driver controls the motor speed as a function of a ±10 V analog input. With an external position sensor and a controller, it is thus possible to set up a very fast, closed-loop system. The M-663 stage with integrated linear encoder (see p. 10-18) can also be run with this driver.

Accessories

For the operation of PILine® stages and piezo linear motors, a drive electronics is required. The driver is necessary to create the ultrasonic oscillations of the piezoceramic actuator of the motor. The choice of the drive electronics depends on

the application and the motion controller used and is therefore not part of delivery of a PLine® stage or motor. The unit with the drive electronics, however, must be ordered at the same time as the stage, so that they can be tuned for optimum performance with each other.

Notes

For more information on the advantages of PLine® systems, see page 10-5.

The products described in this document are in part protected by the following patents:
US-Patent No. 6,765,335

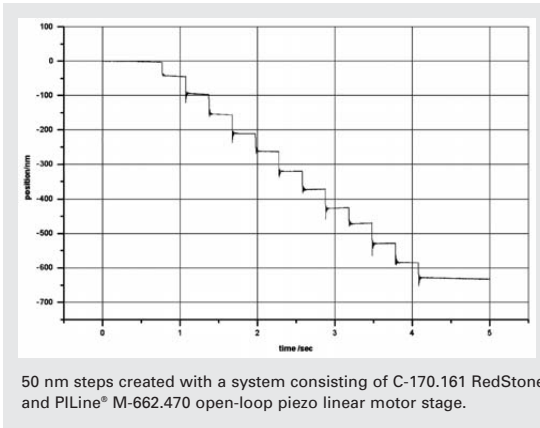
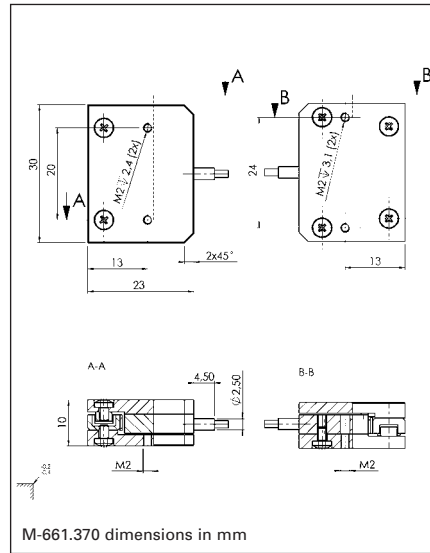
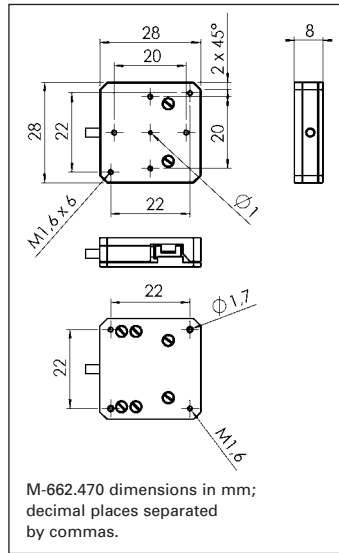

Technical Data

Models	M-661.370	M-662.470	Units	Notes, see p. 10-28
Travel range	18	20	mm	
Design resolution	-	-	µm	A3
Min. incremental motion	0.05	0.05	µm	A4
Bidirectional repeatability	-	-	µm	
Max. velocity	500	500	mm/s	
Max. normal load capacity	5	5	N	B1
Max. push/pull force	1	1	N	B2
Max. holding force	2	2	N	
Operating voltage (drivers)	12	12	V	
Operating voltage (piezo)	60	60	V	
Integrated piezomotor	P-661	P-661		
Operating current	<500	<500	mA	
Weight	0.03	0.03	kg	
Dimensions (L x W x H)	30 x 23 x 10	28 x 28 x 8	mm	
Body material	Aluminum	Aluminum		L
MTBF	>20,000	>20,000		
Recommended driver	C-181.161 (TTL); C-170.161 (TTL); C-185.161 (analog)	C-181.161 (TTL); C-170.161 (TTL); C-185.161 (analog)		see p. 10-24 ff.

- Piezo Actuators
- Nanopositioning & Scanning Systems
- Active Optics / Steering Mirrors
- Tutorial: Piezo-electrics in Positioning
- Capacitive Position Sensors
- Piezo Drivers & Nanopositioning Controllers
- Hexapods / Micropositioning
- Photonics Alignment Solutions
- Motion Controllers

Ceramic Linear Motors & Stages

Index