

M-110.1 · M-111.1 · M-112.1

High-Resolution Linear Stage



- 0.05 μm Minimum Incremental Motion
- 5, 15 and 25 mm Travel Ranges
- Velocity to 1.5 mm/sec.
- Closed-Loop DC Motors and Stepper Motors
- Integrated Hall-Effect Limit and Reference Switches

M-110, M-111 and M-112 are ultra-high resolution motorized translation stages providing linear motion of 5 to 25 mm in an extremely compact package. They feature a precision leadscrew with sub-micron resolution and precision linear ball bearings guaranteeing <math><0.5\ \mu\text{m}</math> straightness of travel.

Stepper and Servo Motors

Both drive options provide a cost effective solution for industrial and OEM environ-

ments. A miniature DC or stepper motor actuates motion via a backlash-compensated lead-screw / nut system and gear-head. To meet the most critical positioning demands, the DC motor is equipped with a high resolution encoder featuring resolution of $0.007\ \mu\text{m}$ per count. The combination of the extremely low stiction / friction construction and high-resolution encoder allows for minimum incremental motion of 50 nanometers at speeds up to 1.5 mm/sec.

Application Examples

- Photonics packaging automation
- Fiber optic instrumentation
- Fiber alignment
- Metrology
- Quality control
- Test equipment
- Micromachining

Non-Contact Limit and Reference Switches

To protect your investment, non-contacting Hall-effect limit and reference switches are installed. Each stage includes a 0.5 m cable with 15-pin sub-D connector and a 3 m extension cable. The connector on the DC-servo versions features integrated line drivers for cable lengths up to 10 meters

between actuator and controller.

M-110, M-111 and M-112 can be combined to XY and XYZ systems for multiaxis alignment applications. A variety of add-on piezo-nanopositioning units are also available, see the "Photonics" section.

Notes

See "Accessories", page 7-92 ff. for adapters, brackets, etc.

Ordering Information

- M-110.1DG**
Micro-Translation Stage, 5 mm, Closed-Loop DC Motor
- M-111.1DG**
Micro-Translation Stage, 15 mm, Closed-Loop DC Motor
- M-112.1DG**
Micro-Translation Stage, 25 mm, Closed-Loop DC Motor
- M-110.12S**
Micro-Translation Stage, 5 mm, 2-Phase Stepper Motor
- M-111.12S**
Micro-Translation Stage, 15 mm, 2-Phase Stepper Motor
- M-112.12S**
Micro-Translation Stage, 25 mm, 2-Phase Stepper Motor

Ask about custom designs!



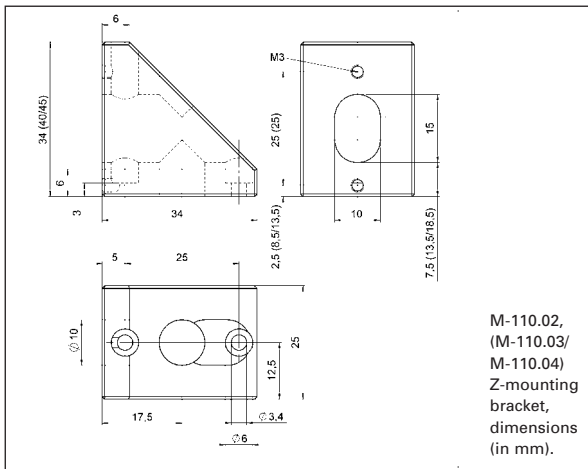
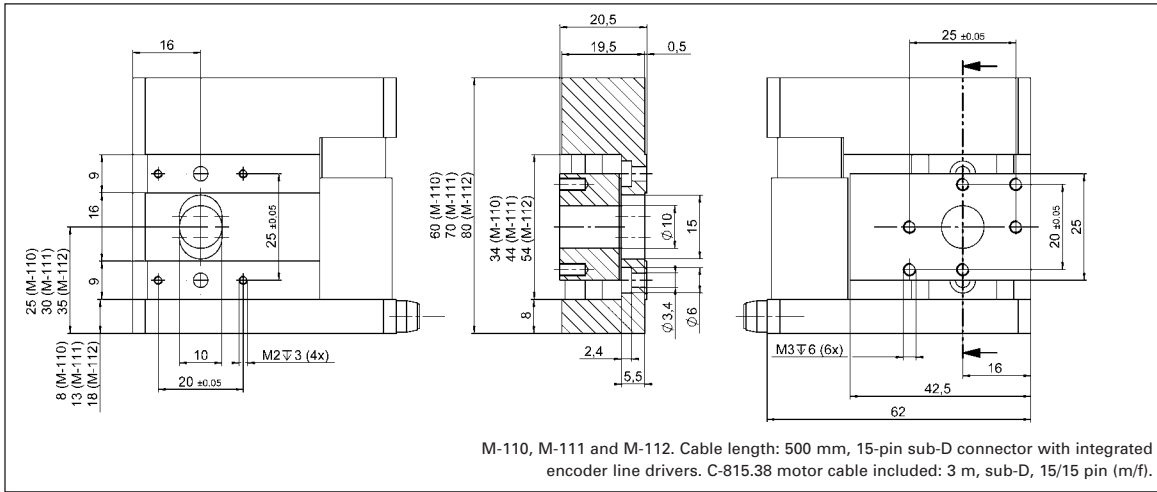

Technical Data

Models	M-110.1DG	M-111.1DG	M-112.1DG	M-110.12S	M-111.12S	M-112.12S	Units*
Travel range	5	15	25	5	15	25	mm
Design resolution	0.007	0.007	0.007	0.012	0.012	0.012	µm
Min. incremental motion	0.05	0.05	0.05	0.05	0.05	0.05	µm
Unidirectional repeatability	0.1	0.1	0.1	0.1	0.1	0.1	µm
Backlash	2	2	2	2	2	2	µm
Max. velocity	1	1.5	1.5	1	1	1	mm/sec
Max. normal load capacity	3	3	2	3	3	2	kg
Max. push/pull force	10	10	10	10	10	10	N
Max. lateral force	10	10	10	10	10	10	N
Encoder resolution	2048	2048	2048	-	-	-	counts/rev.
Motor resolution	-	-	-	1200*	1200*	1200*	steps/rev.
Drive screw pitch	0.4	0.4	0.4	0.4	0.4	0.4	mm/rev.
Gear ratio	28.44444:1	28.44444:1	28.44444:1	28.44444:1	28.44444:1	28.44444:1	
Nominal motor power	0.6	2	2	*	*	*	W
Motor voltage	12	12	12	24*	24*	24*	V
Weight	0.3	0.4	0.5	0.3	0.4	0.5	kg
Recommended motor controllers	C-843, C-848, C-862	C-843, C-848, C-862	C-843, C-848, C-862	C-600, C-630	C-600, C-630	C-600, C-630	

* 2-phase stepper, 24 V chopper voltage, max. 250 mA / phase, 1,200 microsteps with C-600, C-630 controllers.
 * See page 7-106 for notes and explanations.

- Piezo Actuators
- Nanopositioning & Scanning Systems
- Active Optics / Steering Mirrors
- Tutorial: Piezo-electrics in Positioning
- Capacitive Position Sensors
- Piezo Drivers & Nanopositioning Controllers
- Hexapods / Micropositioning**
- Photonics Alignment Solutions
- Motion Controllers
- Ceramic Linear Motors & Stages
- Index